

Overview

Attention can mean several different things. It appears to involve the selection of information, from the vast quantities constantly being processed by the brain, for a different kind of processing by a system of limited processing capacity. The concept of attention is relevant to conscious awareness, and to learning. It is also related to the binding problem, to do with the manner in which concurrently-processed pieces of information retain their relationship to each other. We will consider these concepts, and the attentional networks discovered to date in the brain.

The binding problem

Consider the problem the brain has in representing an arbitrary, complex object — such as a blue pyramid, or your grandmother. If the number of objects we could perceive were limited, the brain could achieve this task by representing each object by the firing of a particular neuron (or group of neurons). This idea is known as the *single neuron doctrine* (Barlow, 1972) or, somewhat facetiously, as the ‘grandmother neuron’ hypothesis; the hypothetical cell would fire at the sight of your grandmother, but no other object (not even anybody else’s grandmother). It will be immediately apparent that we do not possess enough neurons to represent every possible object that we have seen (let alone those that we have not yet seen). With the *possible* exception of faces (for refs see Singer, 1995b), objects must instead be represented by a *population code*, where an object is represented by the firing of many cells in a cell *assembly* (Hebb, 1949); every cell is broadly tuned to sensory stimuli and takes part in many such assemblies. There is ample experimental evidence that sensory and motor coding in the brain involves population coding (e.g. Georgopoulos *et al.*, 1986; Engel *et al.*, 1991).

Consider a simple problem. You view a scene containing a blue triangle and a red square. In a caricature brain, let’s imagine that the scene activates ‘red’ and ‘blue’ detectors (cell assemblies) in a colour-processing area (such as V4), and ‘triangle’ and ‘square’ detectors in one of the many shape-processing areas. Here’s the *binding problem*: how are ‘blue’ and ‘triangle’ bound together so that we can tell the triangle is blue and perceive it as a blue triangular whole? How do we perceive a blue triangle and a red square, but not a blue square or a red triangle?

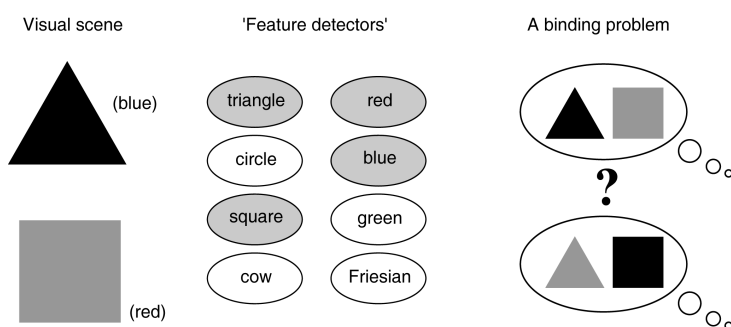

Potential mechanisms for binding; arguments for binding by temporal synchrony

There are two main ways in which groups of neurons constituting a cell assembly could be bound together (Singer *et al.*, 1990; Singer *et al.*, 1993): (1) enhancing the response ‘amplitude’ (firing rate) of the selected neurons, to distinguish them from non-active neurons; (2) synchronizing their discharge (von der Malsburg, 1985; von der Malsburg & Schneider, 1986).

The main difficulty with models based on response amplitude (firing frequency) is the *superposition problem*: it is impossible to represent more than one assembly within the same neuronal network at the same time, because ‘active’ neurons in assembly 1, though they can be distinguished from inactive neurons, cannot be distin-

guished from active neurons in assembly 2. One solution, using our blue triangle example, would be to link the 'shape' and 'colour' areas by a spatial or *positional* code (e.g. 'blue is in the top left of the colour map, triangle is in the top left of the shape map, therefore there's a blue triangle in the top left of visual space') — but this approach is problematic: it requires a further processing stage to co-register these two maps (and is therefore expensive in terms of the number of neurons); it only works for co-registrable spatial maps; and it does not provide a mechanism for interactions between cell assemblies in different areas of space.

Given that arbitrary combinations of features need to be bound together, a dynamic mechanism is required — the leading candidate being a temporal code (von der Malsburg, 1985; von der Malsburg & Schneider, 1986). The proposal was that individual neurons that form part of an assembly should *synchronize* their firing. Assemblies 1 and 2 can be distinguished in this system, because the neurons in assembly 1 are mutually synchronized, but are not synchronized with the neurons in assembly 2 (which themselves are mutually synchronized). (Note that one way for neurons to synchronize for any length of time is to *oscillate* in synchrony — that is, coherently — but synchrony does not require oscillation.)

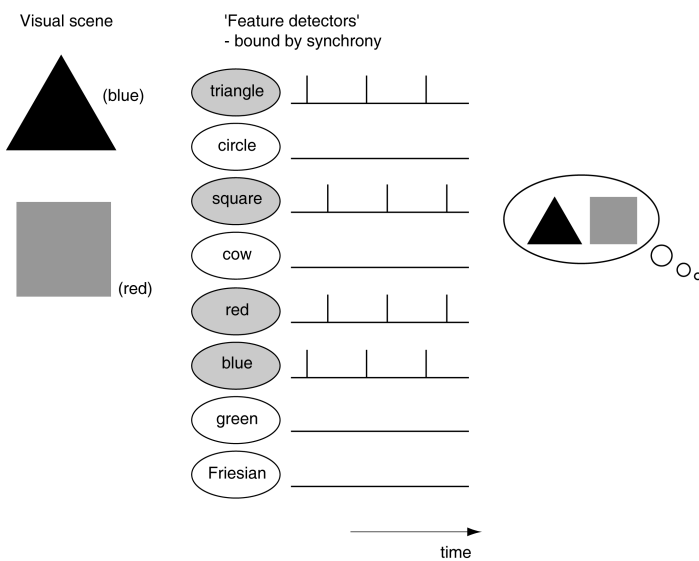

Dynamic binding by temporal synchrony is an extremely powerful concept; it is efficient, stable in simulations, and rapid (it is inevitably faster than selection by firing rates, because a change in firing rate can only be detected by a process of temporal summation and integration). Synchrony has been used as the basis of hypotheses of attention and consciousness (e.g. Crick, 1984; Crick & Koch, 1990b; Crick & Koch, 1990a), and in models of deductive reasoning in connectionist networks (Shastri & Ajjanagadde, 1993; see figure). Does it occur in the brain?

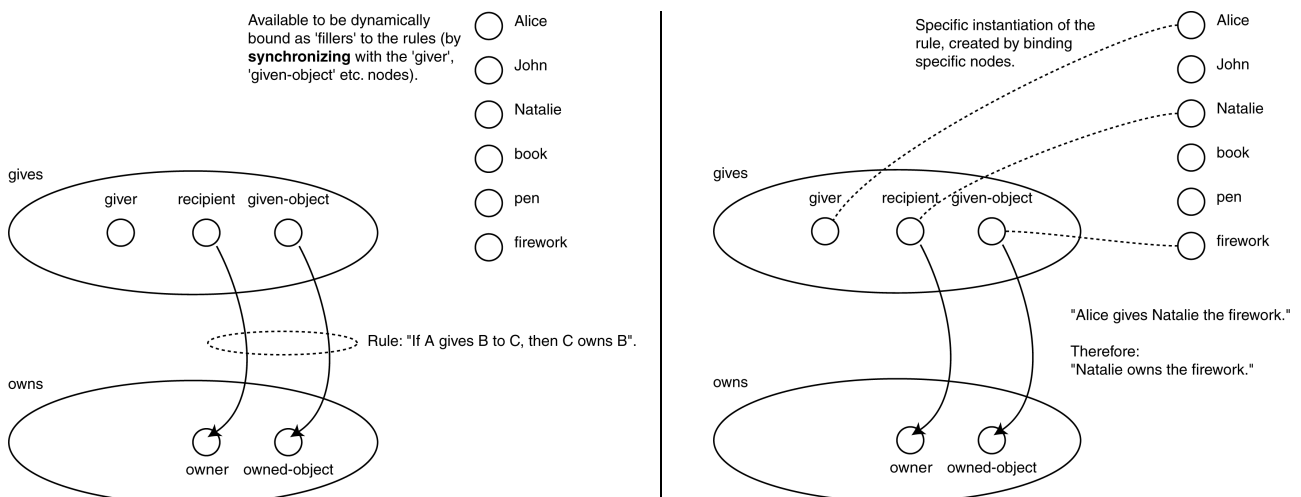

Evidence and mechanisms for binding by temporal synchrony in the brain

Gray, Singer, and colleagues have analysed oscillatory neuronal activity in cat visual cortex (reviewed by Singer *et al.*, 1990; Singer, 1993; Singer, 1995a; Singer, 1995b). Adjacent cortical cells in areas 17, 18, 19, and others synchronize on a millisecond timescale when presented with their preferred stimulus. Synchronization can occur between cortical areas, as well as within them, and can occur between the two hemispheres — this is technically more difficult for the neurons, because the conduction delays between different cortical areas make it harder for cells to synchronize; nevertheless, by means of long-range reciprocal projections (often to local inhibitory interneurons), they do synchronize.

The conditions that induce synchrony in visual cortex closely match the *Gestalt criteria* for perceptual grouping. For example, if two nearby but separate bars of light are moving with the same velocity, they are perceived as a single object, and these conditions induce synchrony. If a single bar of light of a certain orientation A activates some neurons very well, and some less well (because their preferred orientation is slightly different, call it B), these neurons will all nonetheless synchronize. However, if a second bar of light is added with orientation B, the activated cells split into two independently synchronized assemblies (and each of these assemblies can then synchronize independently with other cell groups to form larger assemblies).

If this is the mechanism for binding, then neurons must be able to *detect* and respond to synchrony. As one might expect, therefore, the window for temporal summation

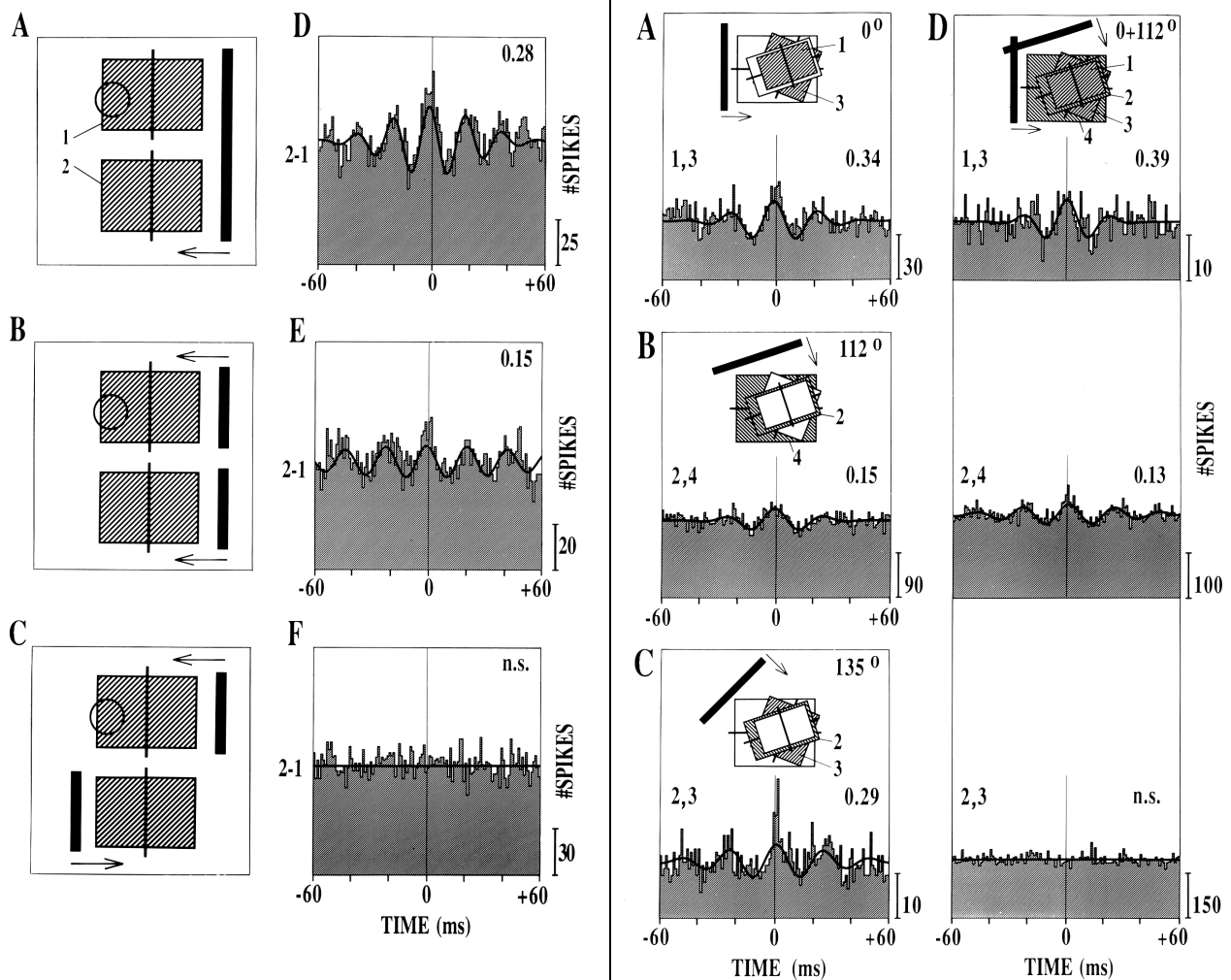

Two sites in cat V1 (Singer, 1995b)7}. Their receptive fields are shown (1, 2). The figures on the right are cross-correlation functions; a peak at time=0 indicates synchrony between the two sites. A single bar of light that activates both sites causes them to synchronize (A, D), as do two bars of light moving in the same direction over the two receptive fields (B, E). Two bars of light moving in different directions do not induce synchrony (C, F).

Four sites in cat V1. They prefer different orientations (insets). If a single bar activates multiple sites, those sites synchronize (A, B, C). If two bars are used (D), some sites prefer bar 1; other prefer bar 2. Those that respond to bar 1 synchronize; those that prefer bar 2 synchronize; but those that prefer bar 1 are not synchronized with those that prefer bar 2. Thus there are two populations, defined by synchrony, responding to the two stimuli.

in cortical neurons may be as short as a few milliseconds (Softky & Koch, 1993). Rate coding and temporal coding are related here: synchronous inputs are more likely to activate a postsynaptic cell and drive it to high firing rates.

Synchrony appears to be dependent upon corticocortical connections, which in mammals develop mainly after birth. Their development obeys experience-dependent rules; thus, if a squint is induced in 3-week-old kittens, their visual intracortical connections are disarrayed — response synchronization no longer occurs between cell groups connected to different eyes, whereas it occurs as normal between cell groups connected to the same eye (König *et al.*, 1993). Remember Hebb: neurons that fire together, wire together. This kind of use-dependent plasticity may also underlie the stabilization of new neuronal assemblies in adults (Singer, 1995a).

There has been extensive interest in synchronous oscillation as a substrate for conscious awareness, particularly with regard to the 40 Hz oscillations that occur in awake cortex (measured locally, or as γ -band frequencies in the EEG). Are 40 Hz oscillations a ‘carrier wave’ generated by oscillations between the thalamus and the cortex that aids or permits cortical synchrony? It seems that cortical γ -band oscillation, occurring either spontaneously or in response to stimulation of the brainstem reticular formation, is necessary for synchronization of neuronal responses in visual cortex (Herculano-Houzel *et al.*, 1999) — in the absence of this 40-Hz oscillation, visual responses are still vigorous but are not synchronized. An important manner in which the reticular formation ‘activates’ cortex may be not to increase or decrease cortical firing, but to permit synchrony (Munk *et al.*, 1996).

Attention

‘Everybody knows what attention is. It is the taking possession by the mind in clear and vivid form of one out of what seem several simultaneous objects or trains of thought.’ So said William James (1890). But attention can mean several things. It can be viewed as the ‘bottom-up’ process by which a subset of sensory stimuli are fully processed by the nervous system (while other stimuli are processed to a lesser extent, e.g. without awareness, though such processing can be substantial). This may involve stimulus competition, but also be modulated by ‘arousal’ systems. Attention can also be viewed as an ‘executive’ or ‘top-down’ capacity — so that one can voluntarily focus on one set of stimuli and exclude distractors; this concept can be applied to vigilance and error detection (see Posner & DiGirolamo, 2000).

Selection by enhancement or suppression of neuronal firing

The magnitude of the responses of neurons in visual cortex can depend upon whether a visual stimulus is being attended to (Moran & Desimone, 1985; Maunsell, 1995; Luck *et al.*, 1997; Luck & Hillyard, 2000). For example, Luck and colleagues established the responses of neurons in V4 to different stimuli (see figure below). They then trained monkeys to attend to one of two spatial locations, both of which were in the receptive field. When two stimuli were present within the RF, the response of the neuron was dramatically affected by which stimulus was being attended to. However, in a different task when only one stimulus was present within the RF (whether or not it was being attended to) there were no such effects of attention.

This kind of attentional modulation has been found in V4, V2, MT, MST, and inferotemporal cortex, but only rarely in V1. Luck & Hillyard (2000) argue that such attentional effects occur whenever two stimuli are present inside a neuron’s RF — in V1, the RFs are so small that it is virtually impossible for an animal to attend to one stimulus that’s inside its RF and simultaneously ignore another stimulus that’s also in its RF.

On the basis of these and related results, Luck *et al.* (1997) suggest that attentional modulation has two stages. In the first stage, attention to an object or location biases activity towards cells representing that object or location, via a top-down mechanism. In a second stage, these selected cells gain an advantage in a competitive process and as a result, cells representing ‘unattended’ features have their activity sup-

pressed (as long as they're close enough to enter into competition with the winning cells, i.e. if they share the same RF). This 'biased competition' theory has been outlined in more detail by Duncan *et al.* (1997) (and also Desimone & Duncan, 1995; Reynolds & Desimone, 1999).

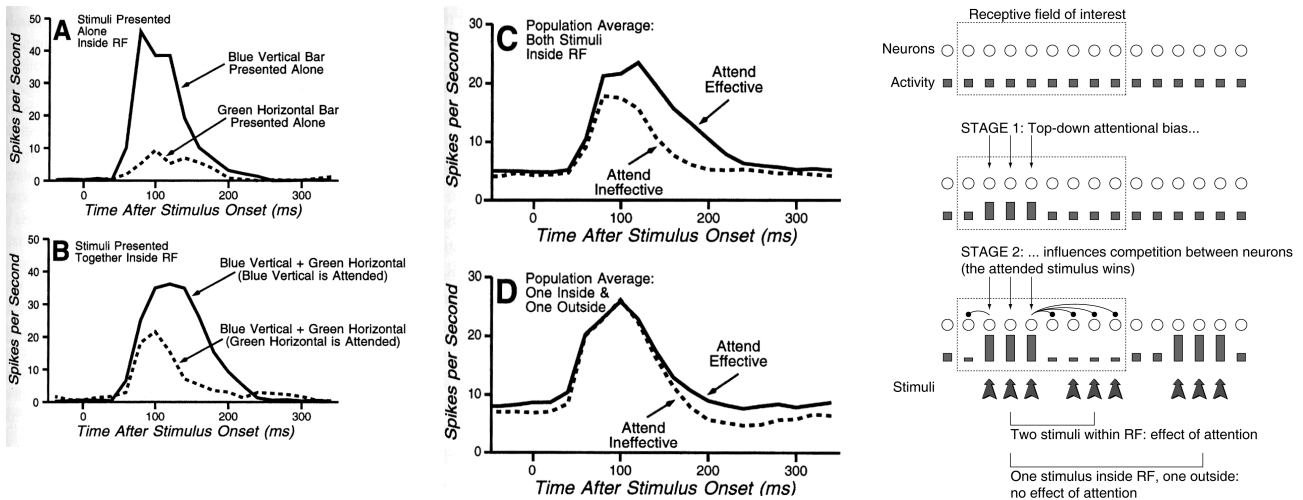

This V4 cell prefers blue vertical bars to green horizontal bars (A). When both a blue and a green stimulus are present, the response depends strongly on which stimulus is being attended to (B). In general, when there are two stimuli inside the receptive field of a cell, the response depends on which stimulus is being attended to (C). If there is only one stimulus inside the RF (whichever one it is), the response doesn't depend on which stimulus is being attended to (D). Far right: one view of this process (based on Luck *et al.*, 1997).

Is there evidence for the first stage of this hypothesis — that there is top-down 'pre-biasing' of the neuronal responses? Yes. The spontaneous activity of V2 and V4 neurons increases when the subject attends to a location within the neurons' RFs (Luck *et al.*, 1997; Reynolds *et al.*, 1999). Similar results have been found using fMRI in humans, examining attention to stimulus *attributes*; for example, attention to colour increases baseline regional cerebral blood flow in V4, and attention to motion increases it in V5, even in the absence of coloured or moving stimuli. When such stimuli were actually presented, the visually-evoked responses were larger when the relevant attribute was being attended to (Chawla *et al.*, 1999).

Is there evidence for the second stage of this hypothesis — that competition takes place between visual stimuli in the absence of attention? Yes. Reynolds *et al.* (1999) examined the response of V2 and V4 neurons to two stimuli. Let's say that the neuron in question preferred stimulus A and responded less to B. Reynolds *et al.* found that the response to A+B was *smaller* than that to A alone, i.e. B competed with A. Similar effects have been observed in the dorsal stream (see Reynolds & Desimone, 1999). Attending to A eliminated the effects of this competition, so that the neuron's response to A+B was the same as that to A alone (see figure, and Reynolds & Desimone, 1999). Interestingly, attending to B caused the neuron's response to A+B to be more like that to B alone (i.e. attention reduced the firing rate) — so attention appears to enhance the *influence* of stimuli on neurons, whether that influence is to

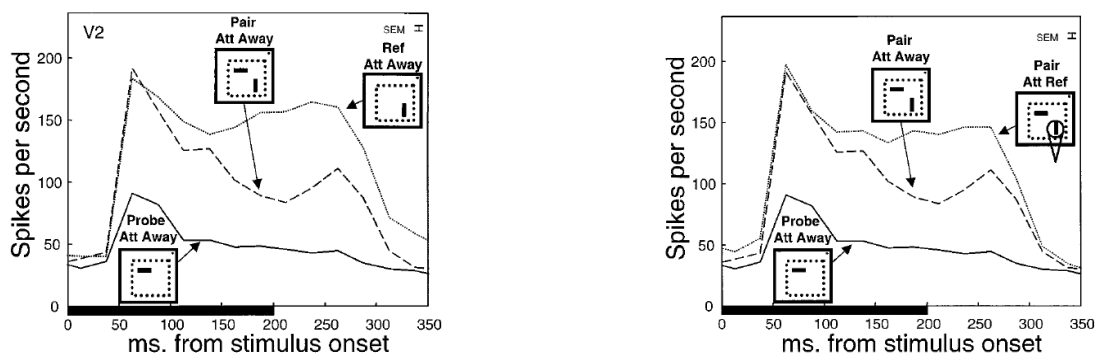

Left: response of a V2 neuron to stimulus A ('ref'), B ('probe'), and A+B ('pair') in the absence of attention (Reynolds *et al.*, 1999). The presence of B reduces the response to A. **Right:** attending to A eliminates the inhibitory effect of B's presence, i.e. attention helps A win the competition.

enhance or reduce firing.

Interactions between rate coding and temporal coding

How does this relate to binding by synchrony? These concepts are hotly debated (compare e.g. Shadlen & Movshon, 1999; Singer, 1999; indeed, this whole issue of *Neuron* is devoted to binding). Attentional enhancement of firing may or may not itself modify binding by synchrony (Luck *et al.*, 1997; Fries *et al.*, 2001). Singer (1999) argues that binding by synchrony provides basic perceptual groupings; groups of features (i.e. objects) thus identified can be selected for attention by other enhancement processes such as those observed by Luck and colleagues.

Attentional control networks in the brain

Control of automatic ('bottom-up') spatial attention

The cued spatial orienting paradigm, or 'Posner task' (Posner *et al.*, 1984; Posner & Petersen, 1990) has been used extensively to study the neural circuits controlling spatial attention (figure below). A cue indicates the location of a forthcoming visual target; the cue is correct on 80% of trials but is incorrect on 20%. When a cue is presented, the subject moves their attention to the side of the cue. When the target arrives, they can then engage it and respond. If the cue is invalid, however, then when the target arrives they must *disengage* attention from the invalid side, *move* it to the correct side, and *engage* the target — and this is therefore slower.

Posner *et al.* (1984) found that posterior parietal cortex lesions specifically impaired the ability to *disengage attention* — lesioned subjects were slower to respond to contralesional stimuli but only if they'd been cued (invalidly) to the ipsilateral side. This suggests that the deficit in *neglect* and *extinction* (remember this from last week?) is due to a failure to disengage attention from ipsilateral stimuli (see Robertson & Rafal, 2000, who also discuss the idea that the right parietal cortex processes 'global' stimuli, while the left parietal cortex processes 'local' stimuli, which we mentioned last week). There is supporting evidence from work with monkeys (Desimone *et al.*, 1990).

Similarly, the superior colliculus (a midbrain structure known to be involved in orienting to salient stimuli, and in eye movement control) appears to be critical for *moving* the focus of attention. Lesions here make subjects slow to respond to both cued and uncued targets in the Posner task. Finally, lesions of the pulvinar (a thalamic nucleus connected to posterior parietal cortex) impair the ability to *engage* contralateral targets. Lesioned monkeys are slow to respond to contralesional stim-

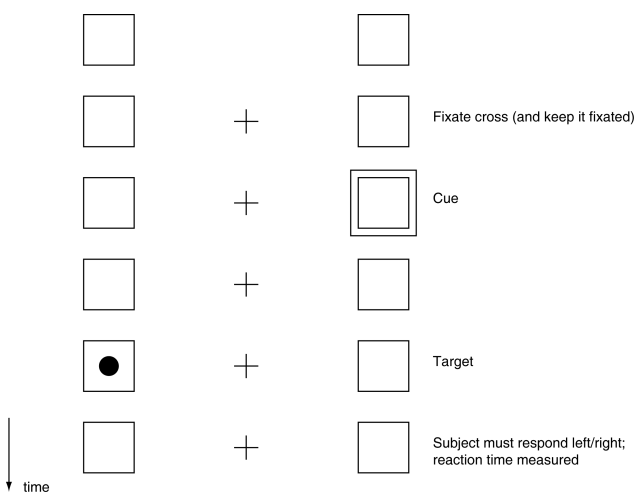

Above: cued spatial orienting paradigm. The cue may be valid (same side as target) or invalid (opposite side, as here). **Right:** parietal lesions impair detection of targets on the contralateral side only when attention has been drawn to the wrong place ('uncued contra' in the figure means 'cue on side ipsilateral to lesion, target on contralateral side', i.e. an invalid cue) (Posner *et al.*, 1984)4).

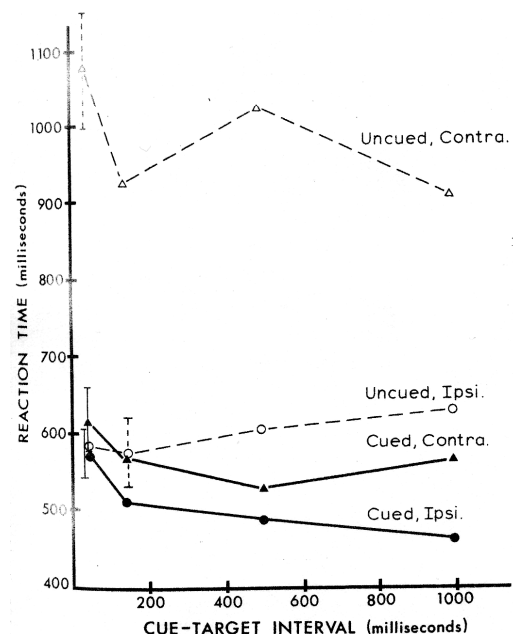
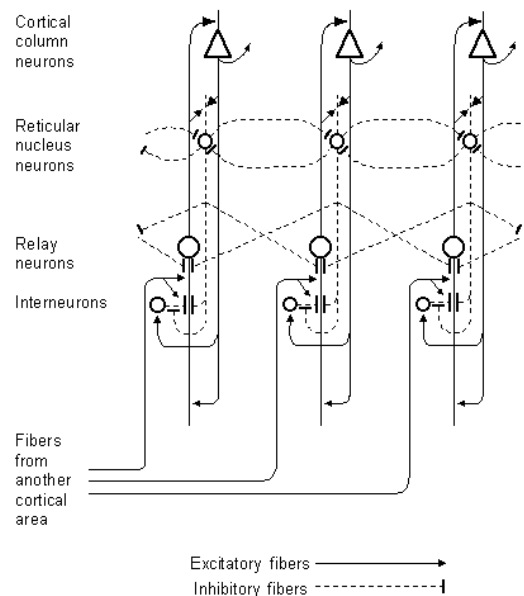
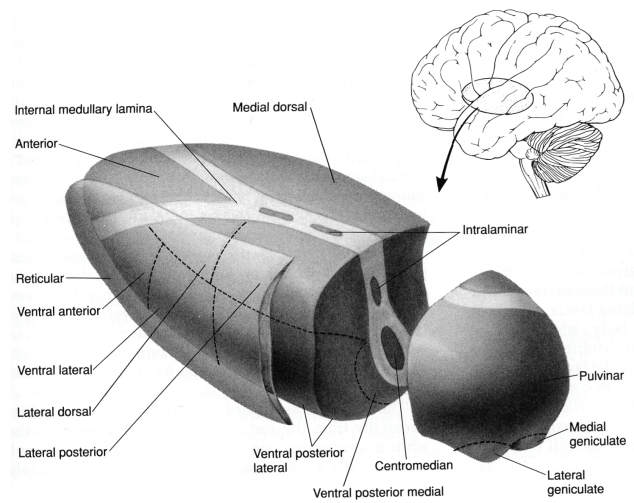
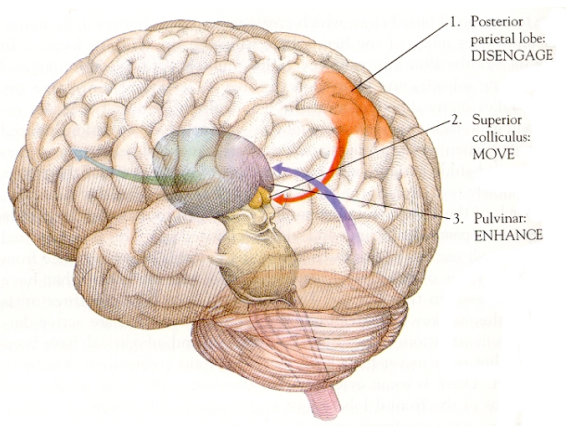

Figure 2. Reaction time for six right parietal patients in the main experiment. Solid lines are for targets on the cued side, and dashed lines are for targets on the uncued side. Triangles are contralateral targets, and circles are ipsilateral targets. Bars indicate ± 1 SE for representative points.

uli, but are faster than normal following an invalid (ipsilateral) cue — one can interpret this as failure of the stimulus to engage attention, but also failure of the cue to engage attention (so it doesn't provide an additional 'distraction' effect).



Above: the principal structures implicated by Posner and colleagues in shifting visuospatial attention in a 'bottom-up' sense. **Top right:** the thalamus, showing the pulvinar and the sheet-like thalamic reticular nucleus (from Kandel *et al.*, 1991). **Right:** might the thalamic reticular nucleus, with its inhibitory influence over all corticothalamic and thalamocortical axons, provide a 'spotlight' of attention by selectively boosting activity in selected cortical areas? (After Crick, 1984; LaBerge, 2000.)

Thalamocortical circuits and attention

LaBerge (2000) discusses how this kind of attentional system might work at a local circuit level; he envisages a 'triangular circuit' of attention whereby the frontal lobes control the site of attention, the thalamus amplifies neuronal activity in the relevant cortical target area (e.g. pulvinar for parietal cortex), and attention is expressed in posterior cortex. The idea that the thalamus is a critical locus in attentional systems is not new. In particular, the thalamic reticular nucleus has attracted a lot of interest; this is a sheet of inhibitory (GABAergic) neurons — the only inhibitory thalamic neurons — through which all corticothalamic and thalamocortical axons pass. It's therefore strategically placed to modulate something like a 'winner-takes-all' competition between different thalamocortical regions (each tries to inhibit the others, and the one with most bottom-up or top-down support wins). Therefore, there's longstanding speculation that the thalamic reticular nucleus acts as an attentional spotlight or gateway (Crick, 1984), and there are some recent hints that the thalamic reticular nucleus responds differentially to attended versus non-attended stimuli (McAlonan *et al.*, 2000).

Control of voluntary ('top-down') spatial attention

Since the landmark work by Posner and colleagues, further evidence has emerged about the circuits that control 'voluntary' attention (Chelazzi & Corbetta, 2000; Corbetta & Shulman, 2002). Corbetta *et al.* (2000) used a variant of the Posner task

in which a central arrow indicates (validly or invalidly) where a target will appear. They found that the superior parietal lobule, especially around the intraparietal sulcus (IPS), was activated when subjects viewed the cue itself — a correlate of their voluntarily directing attention to one of the target locations. This happens whether or not the subjects move their eyes. In contrast, when targets appeared at the non-cued location, on invalid trials — when a ‘bottom-up’ stimulus ‘grabs’ attention — a more posterior region of parietal cortex, the temporo-parietal junction (TPJ) was selectively activated.

Frontal lobe regions also contribute to attentional function. In addition to the superior parietal lobule, the frontal eye fields (FEF), supplementary eye fields, and anterior cingulate cortex all light up in imaging studies in visuospatial tasks. Dorsolateral prefrontal cortex (DLPFC) also influences the activity of visual cortical regions (Fuster *et al.*, 1985). Now, in visual search tasks, it is easy to search for a unique object when it differs from those around it in its orientation, or in its colour — the time to find a stimulus is independent of the number of distractors. suggesting that our brain searches the stimuli in *parallel* search. If we have to search based on the *conjunction* of orientation and colour, however, then the time to find a stimulus depends upon the number of distractors — suggesting an attention-dependent, relatively *serial* search of all the targets in turn (Treisman & Gelade, 1980). The DLPFC is activated when subjects search for visual targets by colour *and* orientation, but not by colour alone or orientation alone (Rees *et al.*, 1997); it may provide an attentional bias to visual cortical areas. A region of superior parietal cortex is also activated by this kind of task — consistent with a spatial attentional search (Corbetta *et al.*, 1995).

Extra snippet — in case you're interested (we won't cover this in the lecture)

Attention, neuromodulation, and learning

To complete our look at aspects of attention, we should mention the role of chemical neuromodulation. Three neuromodulators deserve particular mention.

Noradrenaline (NA)

Noradrenergic neurons, predominantly from the locus coeruleus (LC) in the pons, fire more when an animal is awake than when it's asleep; firing is also induced by important sensory stimuli, such as targets that a monkey must respond to (but not non-target stimuli). Iontophoresis of NA onto cortex suppresses spontaneous activity more than it reduces stimulus-induced activity (Foote *et al.*, 1975); therefore, it may enhance *signal-to-noise ratios*. Aston-Jones and colleagues suggest, from an electrophysiological viewpoint, that LC neurons are important for *vigilance* or *alerting*; they enhance processing of behaviourally important stimuli at the expense of others (Feldman *et al.*, 1997, pp. 327 and 340-344; Aston-Jones *et al.*, 1999, pp. 1403-1407). This accords with rodent studies: cortical NA depletion impairs performance in sustained-attention tasks specifically when distractor stimuli are present, or if the target stimuli are unpredictable in time (see Robbins & Everitt, 1995). Such depletion also impairs learning, particularly under stressful circumstances — Robbins & Everitt (1995), from a behavioural viewpoint, suggest that NA preserves attentional selectivity during arousing or stressful situations. Cortical NA depletion impairs the learning of conditional visual discriminations ('if stimulus X, do A; if stimulus Y, do B'), and may bias rats to learn about contextual (background) stimuli instead of discrete, more predictive cues in conditioning tasks. In humans, the α_2 (autoreceptor) agonist clonidine suppresses NA function, and impairs stimulus discriminability in a continuous-performance task (Coull *et al.*, 1995); it also affects performance on the Posner task (Clark *et al.*, 1989). See Robbins & Everitt (1995) for a more thorough discussion.

Histamine

Histaminergic neurons arise from the tuberomammillary (TM) nucleus of the hypothalamus and their terminals are widely distributed. As you might expect from the sedative effects of H_1 antagonists that cross the blood-brain barrier, histamine is implicated in supporting arousal (Feldman *et al.*, 1997, pp. 451-454): neuronal firing is higher in the active phase of the sleep-wake cycle, antihistamines that penetrate the CNS impair psychomotor performance, inhibition of the TM nucleus may be responsible for some of the sedative effects of general anaesthetics, and so on. An excellent review has recently been provided by Haas & Panula (2003).

Acetylcholine (ACh)

The predominant ACh innervation of the cortex comes from the basal forebrain (notably the nucleus basalis magnocellularis of Meynert, or NBM). ACh has a huge range of effects (Feldman *et al.*, 1997, pp. 268-275). I will mention two here. First, cortical ACh depletion impairs rats' ability to detect brief flashes of light in a visual continuous-performance task (see Robbins & Everitt, 1995; Robbins, 1997).

Second, ACh alters the cortical representation of stimuli; this is relevant to attention. Remember that ACh is required for auditory cortex to change its response to a tone when a guinea pig learns that this tone is followed by electric shock (Weinberger, 1995; Weinberger, 1998) (see also Kilgard & Merzenich, 1998). ACh also appears to regulate the *associability* of stimuli. Associability is a learning-theory concept (e.g. Rescorla & Wagner, 1972; Pearce & Hall, 1980); it determines how much processing is devoted to a conditioned stimulus (CS), and therefore indirectly determines the degree to which new things can be learned about the CS. The Pearce & Hall (1980) model of Pavlovian conditioning suggests that when a CS is reliably followed by an unconditioned stimulus (US), the CS may be worth responding to, but is not worth learning about: animals should confine their attention to learning about stimuli whose consequences are less well known. Associability can be increased by surprising events: for example, if a light is regularly followed by a tone, presentation of the light on its own (with the surprising absence of the tone) is predicted by the Pearce–Hall model to increase the subsequent associability of the light (e.g. Wilson *et al.*, 1992; see Holland, 1997). The ability to *upregulate* associability appears to depend upon the central nucleus of the amygdala (Holland & Gallagher, 1993b; 1993a), its projections to ACh neurons in the NBM (Han *et al.*, 1999), and the cholinergic innervation of the posterior parietal cortex (Bucci *et al.*, 1998). Though the cellular basis of associability is unknown, expansion of the cortical sensory representation of a stimulus (as observed by Weinberger and colleagues) might be a mechanism to increase the associability of a stimulus.

Summary

We have discussed the ways in which the brain might represent stimuli across populations of neurons (the binding problem) and enhance processing of important stimuli (attention). We have considered how areas that process stimuli respond differently to attended and non-attended stimuli, and we have examined the brain's attentional control networks.

Sample essay questions

- What is the binding problem and how is it solved by the brain?
- Critically evaluate the concept of a 'posterior attentional system'.
- How does the concept of attention refine our understanding of the functions of the parietal cortex?
- How have neurobiological studies helped us to understand the deficits shown by patients with 'neglect' or related parietal lobe syndromes?

Suggested reading

Binding and conscious awareness

- Singer (1995b); Engel & Singer (2001) — the binding problem and temporal synchrony
- Singer (1995a) — the circuits underlying synchrony
- Baars (1988) — the best analysis yet of what consciousness is? (For the aficionado.)
- Frith *et al.* (1999) — searches for a neural correlate of consciousness
- Treisman (1999) — review of binding and Treisman's spatial location- and feature-based hypothesis. This special issue of *Neuron* also contains Singer (1999), Reynolds & Desimone (1999), Shadlen & Movshon (1999), and others.
- Robertson (2003) — recent review of binding, and abnormal binding following parietal damage or in synaesthesia

Attention

- Aston-Jones *et al.* (1999) — ch. 54 in *Fundamental Neuroscience*.
- Posner & DiGirolamo (2000); Robertson & Rafal (2000); Chelazzi & Corbetta (2000); Luck & Hillyard (2000); LaBerge (2000); Robbins & Everitt (1995) — chapters in various editions of *The (New) Cognitive Neurosciences*.
- Reynolds & Desimone (1999) — review of the 'biased competition' hypothesis
- Corbetta & Shulman (2002) — recent review of attentional control circuits
- Kastner & Ungerleider (2000) — superb review of visual attention

All references cited in the handout

Don't read all these! Concentrate on the *Suggested Reading* list.

Aston-Jones, G. S., Desimone, R., Driver, J., Luck, S. J. & Posner, M. I. (1999). Attention. In *Fundamental Neuroscience* (Zigmond, M. J., Bloom, F. E., Landis, S. C., Roberts, J. L. & Squire, L. R., eds.), pp. 1385-1409. Academic Press, London.

Baars, B. J. (1988). *A cognitive theory of consciousness*, Cambridge University Press, Cambridge.

Barlow, H. B. (1972). Single units and cognition: a neuron doctrine for perceptual psychology. *Perception* **1**: 371-394.

Bucci, D. J., Holland, P. C. & Gallagher, M. (1998). Removal of cholinergic input to rat posterior parietal cortex disrupts incremental processing of conditioned stimuli. *Journal of Neuroscience* **18**: 8038-8046.

- Chawla, D., Rees, G. & Friston, K. J. (1999). The physiological basis of attentional modulation in extrastriate visual areas. *Nature Neuroscience* **2**: 671-676.
- Chelazzi, L. & Corbetta, M. (2000). Cortical mechanisms of visuospatial attention in the primate brain. In *The New Cognitive Neurosciences*, Second edition (Gazzaniga, M. S., ed.), pp. 667-686. MIT Press, Cambridge, MA.
- Clark, C. R., Geffen, G. M. & Geffen, L. B. (1989). Catecholamines and the covert orientation of attention in humans. *Neuropsychologia* **27**: 131-139.
- Corbetta, M., Kincade, J. M., Ollinger, J. M., McAvoy, M. P. & Shulman, G. L. (2000). Voluntary orienting is dissociated from target detection in human posterior parietal cortex. *Nature Neuroscience* **3**: 292-297.
- Corbetta, M. & Shulman, G. L. (2002). Control of goal-directed and stimulus-driven attention in the brain. *Nat Rev Neurosci* **3**: 201-215.
- Corbetta, M., Shulman, G. L., Miezin, F. M. & Petersen, S. E. (1995). Superior parietal cortex activation during spatial attention shifts and visual feature conjunction. *Science* **270**: 802-805.
- Coull, J. T., Middleton, H. C., Robbins, T. W. & Sahakian, B. J. (1995). Clonidine and diazepam have differential effects on tests of attention and learning. *Psychopharmacology* **120**: 322-332.
- Crick, F. (1984). Functions of the thalamic reticular complex: the searchlight hypothesis. *Proc Natl Acad Sci U S A* **81**: 4586-4590.
- Crick, F. & Koch, C. (1990a). Some reflections on visual awareness. *Cold Spring Harbor Symposia on Quantitative Biology* **55**: 953-962.
- Crick, F. & Koch, C. (1990b). Towards a neurobiological theory of consciousness. *Seminars in Neuroscience* **2**: 263-275.
- Desimone, R. & Duncan, J. (1995). Neural mechanisms of selective visual attention. *Annual Review of Neuroscience* **18**: 193-222.
- Desimone, R., Wessinger, M., Thomas, L. & Schneider, W. (1990). Attentional control of visual perception: cortical and subcortical mechanisms. *Cold Spring Harbor Symposia on Quantitative Biology* **55**: 963-971.
- Duncan, J., Humphreys, G. & Ward, R. (1997). Competitive brain activity in visual attention. *Current Opinion in Neurobiology* **7**: 255-261.
- Engel, A. K., König, P. & Singer, W. (1991). Direct physiological evidence for scene segmentation by temporal coding. *Proc Natl Acad Sci U S A* **88**: 9136-9140.
- Engel, A. K. & Singer, W. (2001). Temporal binding and the neural correlates of sensory awareness. *Trends in Cognitive Sciences* **5**: 16-25.
- Feldman, R. S., Meyer, J. S. & Quenzer, L. F. (1997). *Principles of neuropsychopharmacology*, Sinauer, Sunderland, Massachusetts.
- Footo, S. L., Freedman, R. & Oliver, A. P. (1975). Effects of putative neurotransmitters on neuronal activity in monkey auditory cortex. *Brain Research* **86**: 229-242.
- Fries, P., Reynolds, J. H., Rorie, A. E. & Desimone, R. (2001). Modulation of oscillatory neuronal synchronization by selective visual attention. *Science* **291**: 1560-1563.
- Frith, C., Perry, R. & Lumer, E. (1999). The neural correlates of conscious experience: an experimental framework. *Trends in Cognitive Sciences* **3**: 105-114.
- Fuster, J. M., Bauer, R. H. & Jervey, J. P. (1985). Functional interactions between inferotemporal and prefrontal cortex in a cognitive task. *Brain Research* **330**: 299-307.
- Georgopoulos, A. P., Schwartz, A. B. & Kettner, R. E. (1986). Neuronal population coding of movement direction. *Science* **233**: 1416-1419.
- Haas, H. & Panula, P. (2003). The role of histamine and the tuberomammillary nucleus in the nervous system. *Nat Rev Neurosci* **4**: 121-130.
- Han, J. S., Holland, P. C. & Gallagher, M. (1999). Disconnection of the amygdala central nucleus and substantia innominata/nucleus basalis disrupts increments in conditioned stimulus processing in rats. *Behavioral Neuroscience* **113**: 143-151.
- Hebb, D. O. (1949). *The Organization of Behavior: a Neuropsychological Theory*, Wiley, New York.
- Herculano-Houzel, S., Munk, M. H. J., Neuenschwander, S. & Singer, W. (1999). Precisely synchronized oscillatory firing patterns require electroencephalographic activation. *Journal of Neuroscience* **19**: 3992-4010.
- Holland, P. C. (1997). Brain mechanisms for changes in processing of conditioned stimuli in Pavlovian conditioning: Implications for behavior theory. *Animal Learning & Behavior* **25**: 373-399.
- Holland, P. C. & Gallagher, M. (1993a). Amygdala central nucleus lesions disrupt increments, but not decrements, in conditioned stimulus processing. *Behavioral Neuroscience* **107**: 246-253.
- Holland, P. C. & Gallagher, M. (1993b). Effects of amygdala central nucleus lesions on blocking and unblocking. *Behavioral Neuroscience* **107**: 235-245.
- James, W. (1890). *Principles of Psychology*, Holt, New York.
- Kandel, E. R., Schwartz, J. H. & Jessell, T. M., Eds. (1991). *Principles of Neural Science*. Third edition. Norwalk, CT: Appleton-Lange.
- Kastner, S. & Ungerleider, L. G. (2000). Mechanisms of visual attention in the human cortex. *Annual Review of Neuroscience* **23**: 315-341.
- Kilgard, M. P. & Merzenich, M. M. (1998). Cortical map reorganization enabled by nucleus basalis activity. *Science* **279**: 1714-1718.
- König, P., Engel, A. K., Löwel, S. & Singer, W. (1993). Squint affects synchronization of oscillatory responses in cat visual cortex. *European Journal of Neuroscience* **5**: 501-508.
- LaBerge, D. (2000). Networks of attention. In *The New Cognitive Neurosciences*, Second edition (Gazzaniga, M. S., ed.), pp. 711-724. MIT Press, Cambridge, MA.
- Luck, S. J., Chelazzi, L., Hillyard, S. A. & Desimone, R. (1997). Neural mechanisms of spatial selective attention in areas V1, V2, and V4 of macaque visual cortex. *Journal of Neurophysiology* **77**: 24-42.
- Luck, S. J. & Hillyard, S. A. (2000). The operation of selective attention at multiple stages of processing: evidence from human and monkey electrophysiology. In *The New Cognitive Neurosciences* (Gazzaniga, M. S., ed.), pp. 687-700. MIT Press, Cambridge, MA.
- Maunsell, J. H. R. (1995). The brain's visual world: representation of visual targets in cerebral cortex. *Science* **270**: 764-769.
- McAlonan, K., Brown, V. J. & Bowman, E. M. (2000). Thalamic reticular nucleus activation reflects attentional gating during classical conditioning. *Journal of Neuroscience* **20**: 8897-8901.
- Moran, J. & Desimone, R. (1985). Selective attention gates visual processing in the extrastriate cortex. *Science* **229**: 782-784.
- Munk, M. H., Roelfsema, P. R., König, P., Engel, A. K. & Singer, W. (1996). Role of reticular activation in the modulation of intracortical synchronization. *Science* **272**: 271-274.
- Pearce, J. M. & Hall, G. (1980). A model for Pavlovian learning: variations in the effectiveness of conditioned but not of unconditioned stimuli. *Psychological Review* **106**: 532-552.
- Posner, M. I. & DiGirolamo, G. J. (2000). Attention in cognitive neuroscience: an overview. In *The New Cognitive Neurosciences*, Second edition (Gazzaniga, M. S., ed.), pp. 623-631. MIT Press, Cambridge, MA.
- Posner, M. I. & Petersen, S. E. (1990). The attention system of the human brain. *Annual Review of Neuroscience* **13**: 25-42.
- Posner, M. I., Walker, J. A., Friedrich, F. J. & Rafal, R. D. (1984). Effects of parietal injury on covert orienting of attention. *Journal of Neuroscience* **4**: 1863-1874.
- Rees, G., Frackowiak, R. & Frith, C. (1997). Two modulatory effects of attention that mediate object categorization in human cortex. *Science* **275**: 835-838.
- Rescorla, R. A. & Wagner, A. R. (1972). A theory of Pavlovian conditioning: variations in the effectiveness of reinforcement and non-reinforcement. In *Classical Conditioning II: Current Research and Theory* (Black, A. & Prokasy, W., eds.), pp. 64-99. Appleton-Century-Crofts, New York.
- Reynolds, J. H., Chelazzi, L. & Desimone, R. (1999). Competitive mechanisms subserve attention in macaque areas V2 and V4. *Journal of Neuroscience* **19**: 1736-1753.
- Reynolds, J. H. & Desimone, R. (1999). The role of neural mechanisms of attention in solving the binding problem. *Neuron* **24**: 19-29, 111-125.
- Robbins, T. W. (1997). Arousal systems and attentional processes. *Biological Psychology* **45**: 57-71.
- Robbins, T. W. & Everitt, B. J. (1995). Arousal systems and attention. In *The Cognitive Neurosciences* (Gazzaniga, M. S., ed.), pp. 703-720. MIT Press, Cambridge, MA.
- Robertson, L. C. (2003). Binding, spatial attention and perceptual awareness. *Nat Rev Neurosci* **4**: 93-102.
- Robertson, L. C. & Rafal, R. (2000). Disorders of visual attention. In *The New Cognitive Neurosciences*, Second edition (Gazzaniga, M. S., ed.), pp. 633-649. MIT Press, Cambridge, MA.
- Shadlen, M. N. & Movshon, J. A. (1999). Synchrony unbound: a critical evaluation of the temporal binding hypothesis. *Neuron* **24**: 67-77, 111-125.
- Shastri, L. & Ajjanagadde, V. (1993). From simple associations to systematic reasoning: a connectionist representation of rules, variables and dynamic bindings using temporal synchrony. *Behavioral and Brain Sciences* **16**: 417-494.
- Singer, W. (1993). Synchronization of cortical activity and its putative role in information processing and learning. *Annual Review of Physiology* **55**: 349-374.
- Singer, W. (1995a). Development and plasticity of cortical processing architectures. *Science* **270**: 758-764.
- Singer, W. (1995b). Time as coding space in neocortical processing: a hypothesis. In *The Cognitive Neurosciences* (Gazzaniga, M. S., ed.), pp. 91-104. MIT Press, Cambridge, MA.
- Singer, W. (1999). Neuronal synchrony: a versatile code for the definition of relations? *Neuron* **24**: 49-65, 111-125.
- Singer, W., Artola, A., Engel, A. K., König, P., Kreiter, A. K., Löwel, S. & Schillen, T. B. (1993). Neuronal representations and temporal codes. In *Exploring Brain Functions: Models in Neuroscience* (Poggio, T. A. & Glaser, D. A., eds.), pp. 179-195. Wiley.
- Singer, W., Gray, C., Engel, A. K., König, P., Artola, A. & Bröcher, S. (1990). Formation of cortical cell assemblies. *Cold Spring Harbor Symposia on Quantitative Biology* **55**: 939-952.
- Softky, W. R. & Koch, C. (1993). The highly irregular firing of cortical cells is inconsistent with temporal integration of random EPSPs. *Journal of Neuroscience* **13**: 334-350.
- Treisman, A. (1999). Solutions to the binding problem: progress through controversy and convergence. *Neuron* **24**: 105-110, 111-125.
- Treisman, A. M. & Gelade, G. (1980). A feature-integration theory of attention. *Cognit Psychol* **12**: 97-136.
- von der Malsburg, C. (1985). Nervous structures with dynamical links. *Berl. Bunsenges. Phys. Chem.* **89**: 703-710.
- von der Malsburg, C. & Schneider, W. (1986). A neural cocktail-party processor. *Biological Cybernetics* **54**: 29-40.
- Weinberger, N. M. (1995). Retuning the brain by fear conditioning. In *The Cognitive Neurosciences* (Gazzaniga, M., ed.), pp. 1071-1089. MIT Press, Cambridge, Massachusetts.
- Weinberger, N. M. (1998). Tuning the brain by learning and by stimulation of the nucleus basalis. *Trends in Cognitive Sciences* **2**: 271-273.
- Wilson, P. N., Boumphrey, P. & Pearce, J. M. (1992). Restoration of the orienting response to a light by a change in its predictive accuracy. *Quarterly Journal of Experimental Psychology, Section B - Comparative and Physiological Psychology* **44**: 17-36.